

LC-R067P

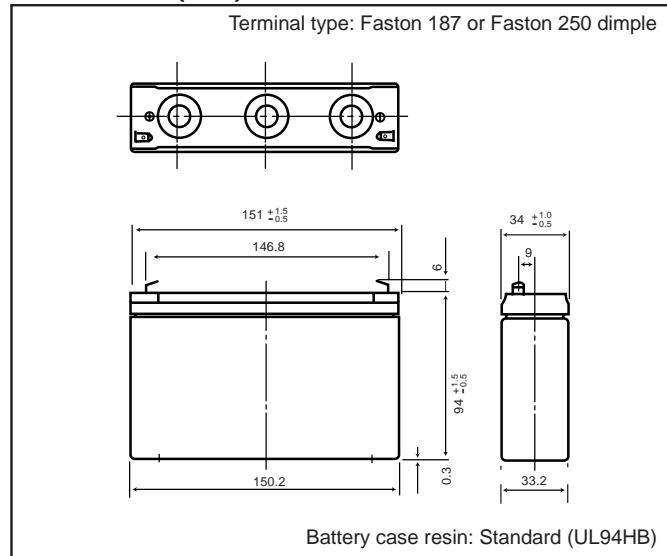

For main and standby power supplies.
Expected trickle life: over 3 years at 25°C, Approx. 5 years at 20°C.

Dimensions (mm)



Specifications

Nominal voltage		6V
Rated capacity (20 hour rate)		7Ah
Dimensions	Length	151 mm
	Width	34 mm
	Height	94 mm
	Total Height	100 mm
Approx. mass		1.13 kg

Discharge characteristics (25°C) (Note)

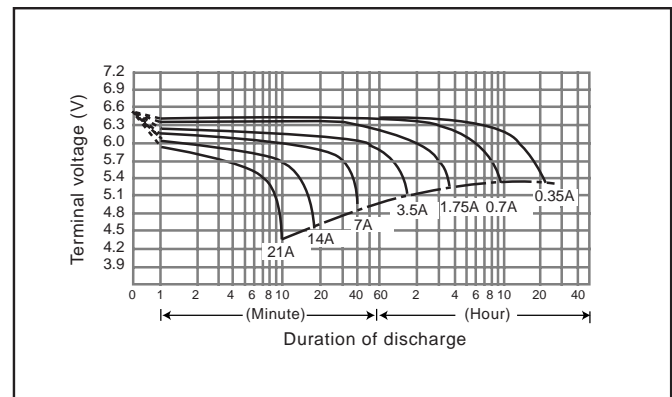

Characteristics

Capacity (note) (25°C)	20 hour rate (350mA)	7.0Ah	
	10 hour rate (660mA)	6.6Ah	
Dimensions	5 hour rate (1220mA)	6.1Ah	
	1 hour rate (4700mA)	4.7Ah	
	1.5 hour rate discharge Cut-off voltage 5.25 V	3.3A	
Internal resistance	Fully charged battery (25°C)	Approx. 13mΩ	
Temperature dependency of capacity (20 hour rate)	40°C	102%	
	25°C	100%	
	0°C	85%	
Self discharge (25°C)	-15°C	65%	
	Residual capacity after standing 3 months	91%	
	Residual capacity after standing 6 months	82%	
Charge Method (Constant Voltage)	Cycle use (Repeating use)	Initial current	2.8 A or smaller
		Control voltage	7.25V to 7.45 V (per 6V cell 25°C)
	Trickle use	Initial current	1.05 A or smaller
		Control voltage	6.8V to 6.9V (per 6V cell 25°C)

Duration of discharge vs. Discharge current (Note)

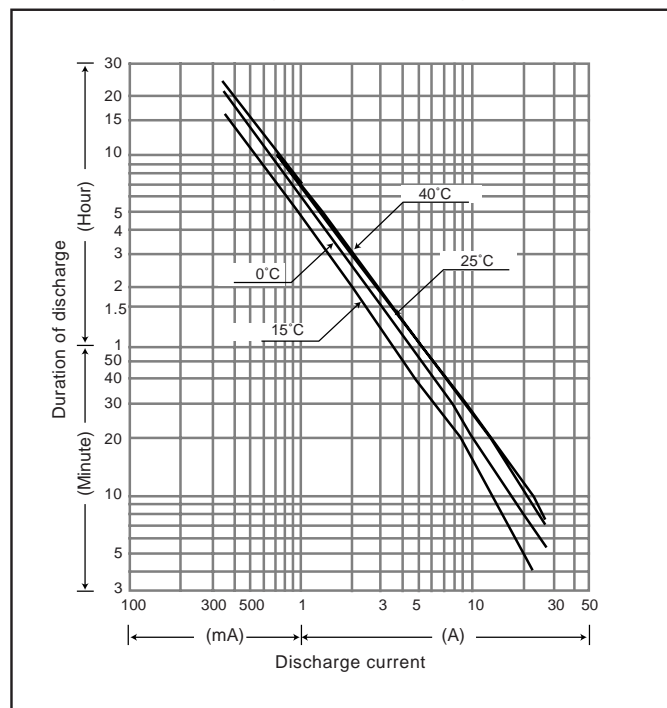

(Note) The above characteristics data are average values obtained within three charge/discharge cycles, not the minimum values.