

LC-P067R2P

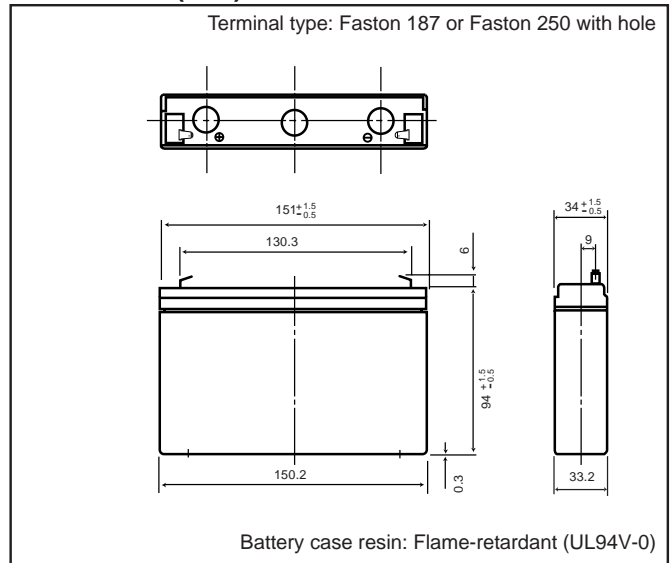

For standby power supplies. Expected trickle life: Approx. 6 years at 25°C, Approx. 10 years at 20°C.

Dimensions (mm)



Specifications

Nominal voltage		6V
Rated capacity (20 hour rate)		7.2Ah
Dimensions	Length	151 mm
	Width	34 mm
	Height	94 mm
	Total Height	100 mm
Approx. mass		1.3 kg

* The total height of #250 terminal is 101.5mm.

Characteristics

Capacity ^(note) (25°C)	20 hour rate (360mA)	7.2Ah	
	10 hour rate (680mA)	6.8Ah	
Internal resistance	5 hour rate (1260mA)	6.3Ah	
	1 hour rate (4900mA)	4.9Ah	
	1.5 hour rate discharge	3.5A	
	Cut-off voltage 5.25 V		
Temperature dependency of capacity (20 hour rate)	Fully charged battery (25°C)	Approx. 20mΩ	
	40°C	102%	
	25°C	100%	
	0°C	85%	
Self discharge (25°C)	-15°C	65%	
	Residual capacity after standing 3 months	91%	
	Residual capacity after standing 6 months	82%	
	Residual capacity after standing 12 months	64%	
Charge Method (Constant Voltage)	Trickle use	Initial current	1.08 A or smaller
		Control voltage	6.8V to 6.9V (per 6V cell 25°C)

(Note) The above characteristics data are average values obtained within three charge/discharge cycles, not the minimum values.

(Note) For cycle use of the battery, please contact us in advance.

Discharge characteristics (25°C) (Note)

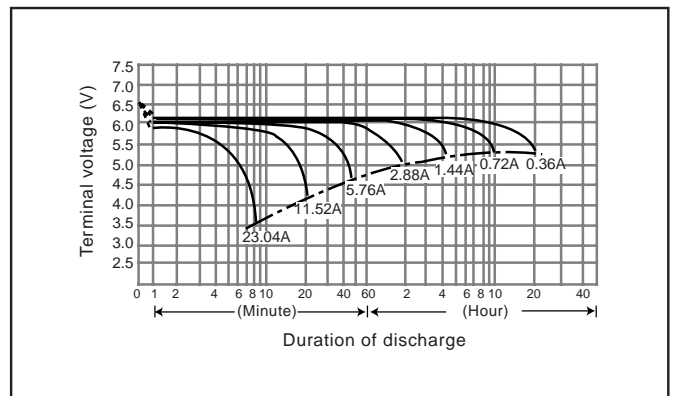

Duration of discharge vs. Discharge current (Note)

